

Deye[®]

User Manual

Spring series LFP Battery

RW-F10.6



Version V1.2

About This Manual

The manual mainly describes the product information, guidelines for installation, operation, and maintenance. The manual cannot include complete information about the solar photovoltaic-energy storage hybrid system.

How to Use This Manual

Read the manual and other related documents before performing any operation on the battery. Documents must be stored carefully and be always available.

Content may be updated or modified periodically due to product update iterations. The manual is subject to change without prior notice. The latest manual can be acquired via service-ess@deye.com.cn (www.deyeess.com).

1 Safety Introductions



Reminding

- 1) It is very important and necessary to read the user manual carefully (in the accessories) before installing or using battery. Failure to do so or to follow any of the instructions or warnings in this document can result in electrical shock, serious injury, or death, or can damage battery, potentially rendering it inoperable.
- 2) If the battery is stored for long time, it is required to charge them every six months, and the SOC should be no less than 50%.
- 3) Battery needs to be recharged within 48 hours after fully discharged.
- 4) Do not expose cable outside.
- 5) All the battery terminals must be disconnected for maintenance.
- 6) Please contact the supplier within 24 hours if there is something abnormal.
- 7) Do not use cleaning solvents to clean battery.
- 8) Do not expose battery to flammable or harsh chemicals or vapors.
- 9) Do not paint any part of Battery, include any internal or external components.
- 10) Do not connect battery with PV solar wiring directly.
- 11) The warranty claims are excluded for direct or indirect damage due to items above.
- 12) Any foreign object is prohibited to insert into any part of battery.



Li-ion





Warning

1.1 Before Connecting

- 1) After unpacking, please check product and packing list first, if product is damaged or lack of parts, please contact with the local retailer.
- 2) Before installation, be sure to cut off the grid power and make sure the battery is in the turned-off mode.
- 3) Wiring must be correct, do not mistake the positive and negative cables, and ensure no short circuit with the external device.
- 4) It is prohibited to connect the battery and AC power directly.
- 5) Battery system must be well grounded and the resistance must be less than 1Ω .
- 6) Please ensure the electrical parameters of battery system are compatible to related equipment.
- 7) Keep the battery away from water and fire.

1.2 In Using

- 1) If the battery system needs to be moved or repaired, the power must be cut off and the battery is completely shut down.
- 2) It is prohibited to connect the battery with different type of Battery.
- 3) It is prohibited to put the batteries working with faulty or incompatible inverter.
- 4) It is prohibited to disassemble the battery.
- 5) In case of fire, only dry fire extinguishers can be used. Liquid fire extinguishers are forbidden.
- 6) Please do not open, repair, or disassemble the battery except staffs from DEYE or authorized by DEYE. We do not undertake any consequences or related responsibility which because of violation of safety operation or violating of design, production, and equipment safety standards.

2 Introduction

- ◇ RW-F10.6 lithium iron phosphate battery is one of new energy storage products developed and produced by DEYE, it can be used to support reliable power for various types of equipment and systems.
- ◇ RW-F10.6 is especially suitable for application scene of high power, limited installation space and long cycle life.
- ◇ RW-F10.6 has built-in BMS battery management system, which can manage and monitor cells information including voltage, current and temperature. What's more, BMS can balance cells charging and discharging to extend cycle life.
- ◇ Multiple batteries can connect in parallel to expand capacity and power in parallel for larger capacity and longer power supporting duration requirements.

2.1 Product Features

- 1) The whole module is non-toxic, non-polluting, and environmentally friendly.
- 2) Cathode material is made from LiFePO₄ with safety performance and long cycle life.
- 3) Battery management system (BMS) has protection functions including over-discharge, over-charge, over-current and high & low temperature.
- 4) The system can automatically manage charge and discharge state and balance current and voltage of each cell.
- 5) Flexible configuration, multiple battery modules can be in parallel for expanding capacity and power.
- 6) Adopted self-cooling mode rapidly reduced system entire noise.
- 7) The module has less self-discharge, up to 6 months without charging it on shelf, no memory effect, excellent performance of shallow charge and discharge.
- 8) Battery module communication address auto networking, easy maintenance, support remotely monitoring and upgrade the firmware.
- 9) High-power density: flat design, wall-mounted and floor-mount, saving installation space.

2.2 Product Overview

This section details the front and side panel of the interface functions.

RW-F10.6 Product Interface

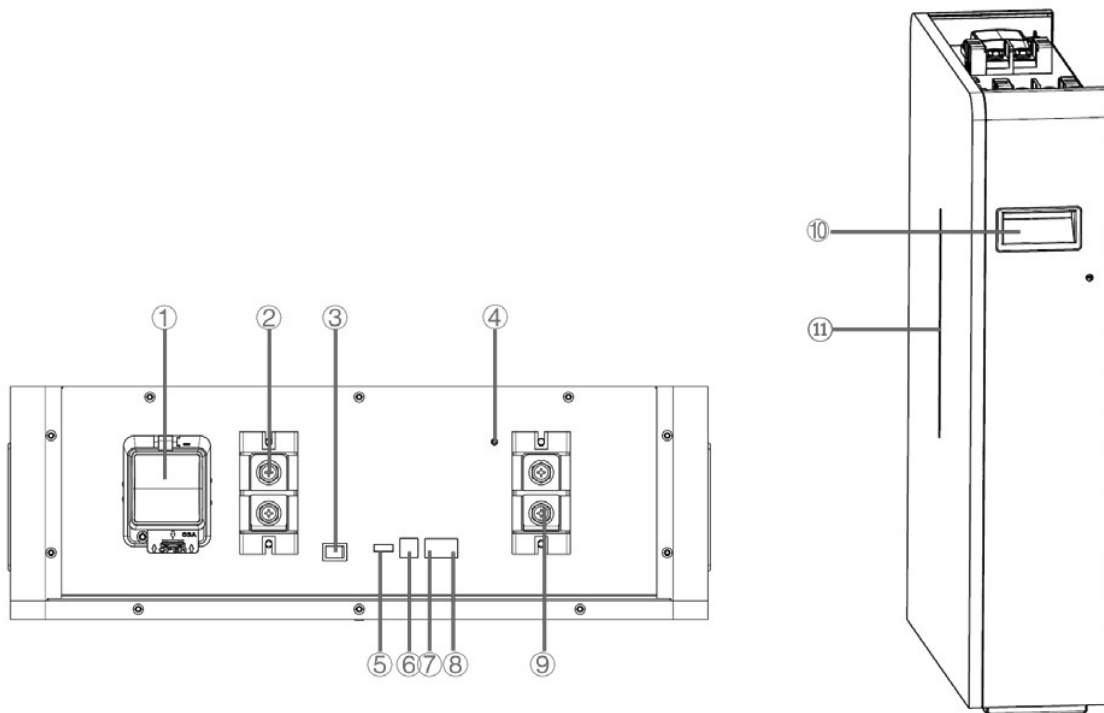

1. Micro circuit breaker	7. Parallel communication port IN
2. Battery positive	8. Parallel communication port OUT
3. BMS Switch	9. Battery negative

4. Grounding bolt	10. Handle
5. DRY CONTACT output port	11. Battery indicators
6. Inverter CAN/RS485 port PCS	

BMS Switch 

BMS Switch: to turn ON/OFF the whole battery BMS standby, no power output.

PCS

Inverter communication terminal: (RJ45 port) follow the CAN protocol (baud rate: 500K), used to output battery information to the inverter.

Definition of PCS Port Pin

No.	PCS Port Pin
1	485-B
2	485-A
3	--
4	CANH
5	CANL
6	--
7	485-A
8	485-B



IN

Parallel Communication Terminal: (RJ45 port) Connect "out" Terminal of Previous battery for communication between multiple parallel batteries.

Definition of IN Port Pin

No.	PCS Port Pin
1	CANL
2	CANH
3	DI+
4	DI-
5	DI-
6	DI+
7	CANH
8	CANL



OUT

Parallel Communication Terminal: (RJ45 port) Connect "IN" Terminal of Next battery for communication between multiple parallel batteries.

Definition of Out Port Pin

No.	Out Port Pin
1	CANL
2	CANH
3	DO+
4	DO-
5	DO-
6	DO+
7	CANH
8	CANL



LED Status Indicators Instructions

Error : Red on the right and green on the left, long bright if equipment protected.

SOC : Battery capacity indicator, green light strip.

Condition	Error	SOC 0%~20%	SOC 0%~40%	SOC 0%~60%	SOC 0%~80%	SOC 0%~100%
SOC						
Power off	off					
Charge	off	Show SOC & highest LED blink				
Discharge or Idle	off	Show SOC & long bright				
Alarm	off	Other LEDs are same as above.				
System error/Protect		Other LEDs are same as above.				
Upgrade	Blink Fastly					
Critical Error	Blink Slowly					

Grounding bolt

For the battery connecting to the PE.

BMS function:

Protection and Alarm	Management and Monitor
Charge/Discharge End	Intelligent Protect Mode
Charge Over Voltage	Intelligent Charge Mode
Discharge Under Voltage	Protect, Charge Current Limit
Charge/Discharge Over Current	Intelligent Protect Mode
High/Low Temperature(cell/BMS)	Intelligent Protect Mode
Short Circuit	Protect

2.3 Product Size (unit: mm)

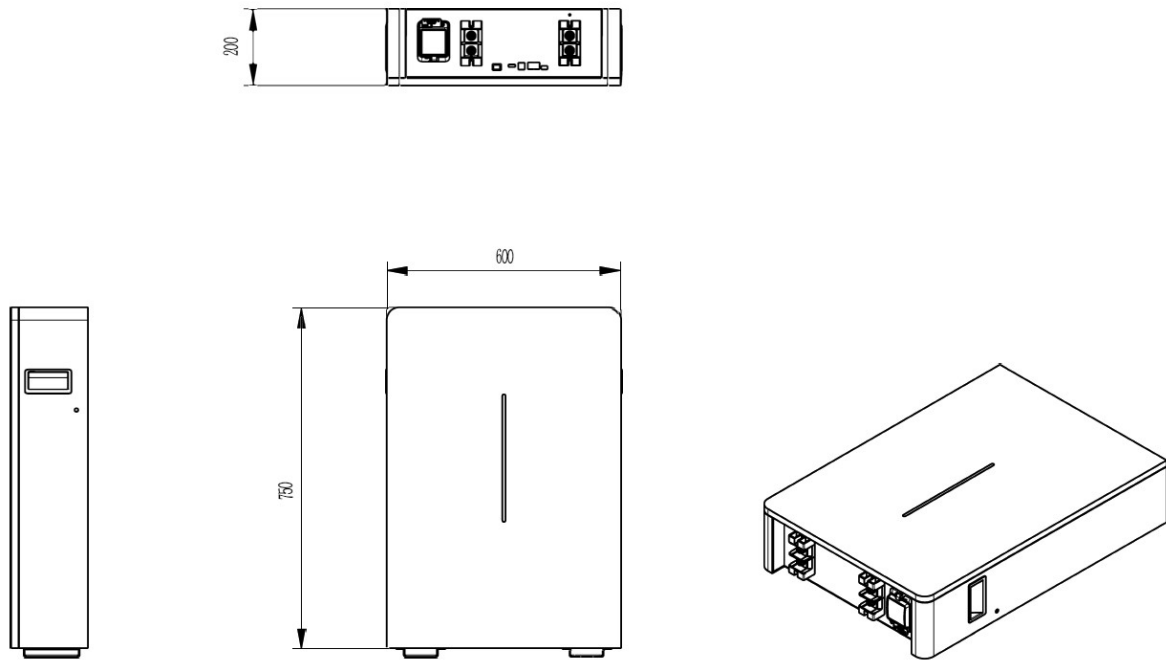

2.4 Technical Data

Main Parameter		RW-F10.6
Battery Chemistry		LiFePO4
Capacity (Ah)		208
Scalability		Max.32 pcs pack (Max.340kWh) in parallel
Nominal Voltage (V)		51.2
Operating Voltage(V)		43.2~57.6
Energy (kWh)		10.64
Usable Energy (kWh) ^[1]		9.58
Charge/Discharge Current (A)	Recommend ^[2]	104
	Max. ^[2]	Discharge: 250/Charge:200
	Peak(2mins,25°C)	300(2mins)
Other Parameter		
Recommend Depth of Discharge		90%
Dimension (W/H/D, mm)		600×750×200mm(Without hanging board)
Weight Approximate(kg)		99
Master LED indicator		LED(SOC:20%~SOC100% and working state)
IP Rating of enclosure		IP20
Working Temperature		Charge: 0 ~ 55°C Discharge: -20°C ~ 55°C
Storage Temperature		0 ~ 35°C
Humidity		5%~95%
Altitude		≤2000m
Installation		Wall-Mounted, Floor-Mounted
Communication Port		CAN2.0, RS485
Certification		UN38.3, MSDS,CE,CB

[1] DC Usable Energy, test conditions: 90% DOD, 0.5C charge & discharge at 25°C. System usable energy may vary due to system configuration parameters.

[2] The current is affected by temperature and SOC.

2.5 Product application solutions

The following illustration shows basic application of this battery.

It also includes following devices to have a complete running system.

- Generator or Utility
- PV modules
- Hybrid Inverters (Charge & Discharge)

Consult with your system integrator for other possible system architectures depending on your requirements.

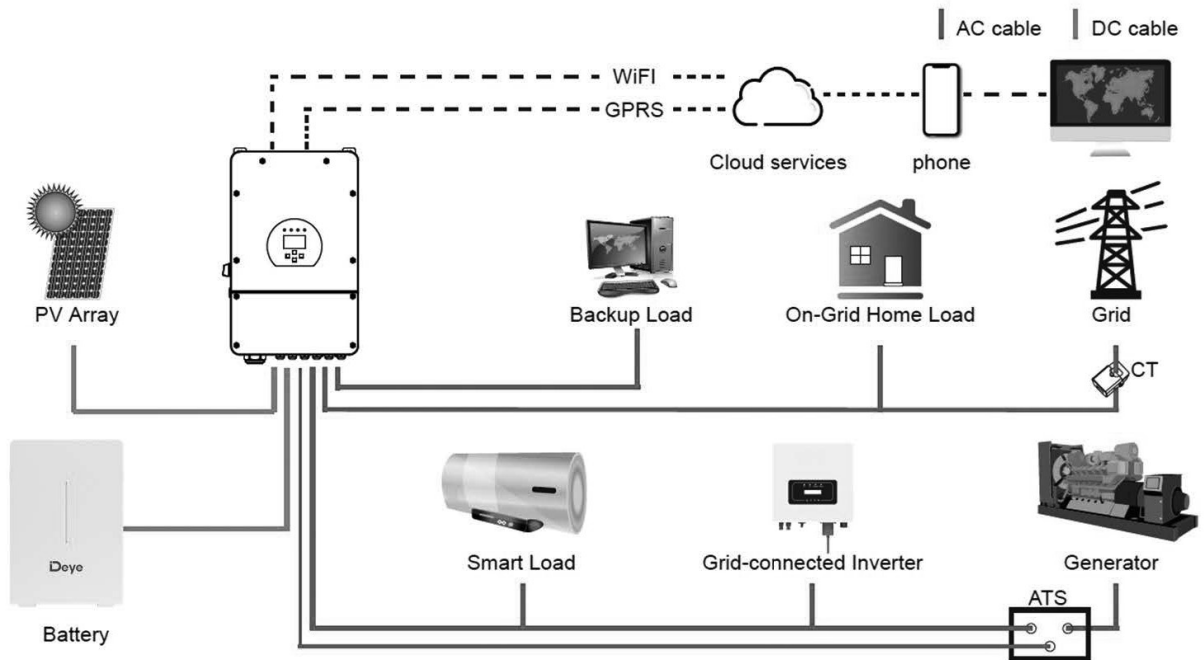

The picture is only an effect picture, please refer to the actual product, the final interpretation right belongs to DEYE.

3 Parts List

Check the equipment before installation. Please make sure nothing is damaged in the package. You should have received the items in the following package.

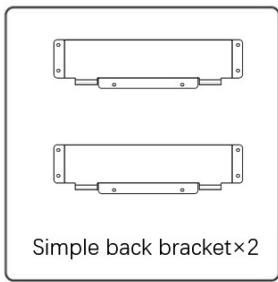
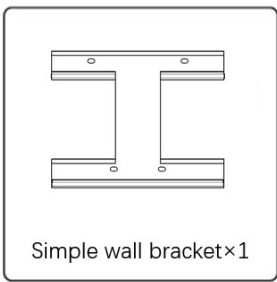
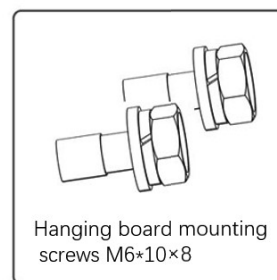
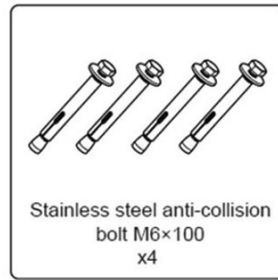
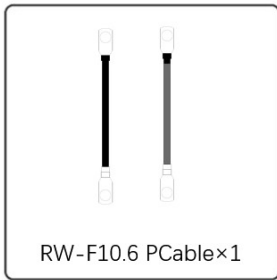
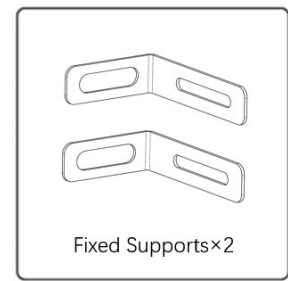
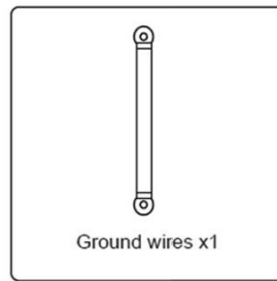
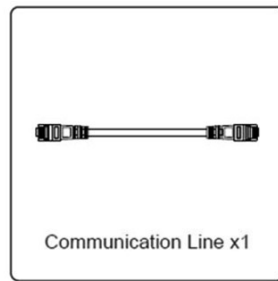
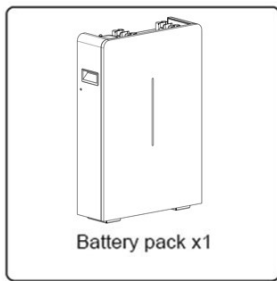













4 Preparations for Installation

4.1 Explanation of Symbol



DANGER/HIGH VOLTAGE INSIDE

CAUTION:

- Do not disassemble or alter the battery in any way.
- Do not use the battery for purposes not described in its documentation.
- Do not drop, strike, puncture, or step on the battery.
- In case of electrolyte leakage, keep leaked electrolyte away from contact with eyes or skin, immediately clean with water and seek help from a doctor.
- Do not put the battery into a fire. Do not use it or leave it in a place near fire, heaters, or high temperature sources.
- Do not submerge the battery in water, or expose it to moisture.
- Do not allow the terminals to contact exposed wire or metal.
- The battery is heavy and can cause injury if not handled safely.
- Keep out of reach of children or animals.

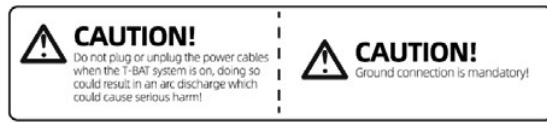

4.2 Tools

These tools are required to install the battery.



Torque Screwdriver



Phillips Screwdriver



Hexagon Wrench



Phillips Screwdriver



Slotted Screwdriver



Torque Wrench

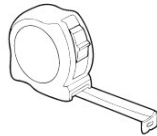

Tape Measure



Driller



Pencil or Marker

NOTE:

Use properly insulated tools to prevent accident tale electric shock or short circuits. If insulated tools are not available, cover the entire exposed metal surfaces of the available tools, except their tips, with electrical tape.

4.3 Safety Gear

It is recommended to wear the following safety gear when dealing with the battery pack.



Safety gloves



Safety goggles



Safety shoes

5 Mounting instructions

5.1 Installation Precaution

Lithium battery is designed for outdoor use (IP65). But please avoid direct sunlight, rain exposure, snow laying up during installation and operation.

Please make sure the installation site meets below conditions:

- ◆ Not in direct sunlight.
- ◆ Not in areas where highly flammable materials are stored.
- ◆ Not in potential explosive areas.
- ◆ Not in the cool air directly.
- ◆ Not higher than altitude of about 2000 meters above sea level.
- ◆ Not in environment of precipitation or humidity (>95%).

5.2 Installation Location

Make sure that the installation location meets the following conditions:

- ◇ The area is completely water proof.
- ◇ The wall is flat and level.
- ◇ There are no flammable or explosive materials.
- ◇ The ambient temperature is within the range from -20°C to 50°C.
- ◇ The temperature and humidity are maintained at a constant level.
- ◇ There is minimal dust and dirt in the area.
- ◇ The distance from heat source is more than 2 meters.
- ◇ The distance from air outlet of inverter is more than 0.5 meters.
- ◇ Do not cover or wrap the battery case or cabinet.
- ◇ Do not place at a children or pet touchable area.
- ◇ The installation area shall avoid of direct sunlight.
- ◇ There are no mandatory ventilation requirements for battery module, but please avoid of installation in confined area. The aeration shall avoid of high salinity, humidity, or temperature.



CAUTION

If the ambient temperature is outside the operating range, the battery pack stops operating to protect itself. The optimal temperature range for the battery pack to operate is 15°C to 35°C. Frequent exposure to harsh temperatures may deteriorate the performance and life of the battery pack.

5.3 Mounting the Battery



CAUTION

Remember that this battery is heavy! Please be careful when lifting out from the package.

5.3.1 Wall-Mounted method

a) Keep a distance of more than 400mm from the ground. After fixing the wall bracket, put a sticker on the right side (between 75 and 80mm). And a sticker on the top of it (between 110 and 120mm). Mark the drill hole location at the appropriate location.

The installation location description should meet the size requirements of the figure below:

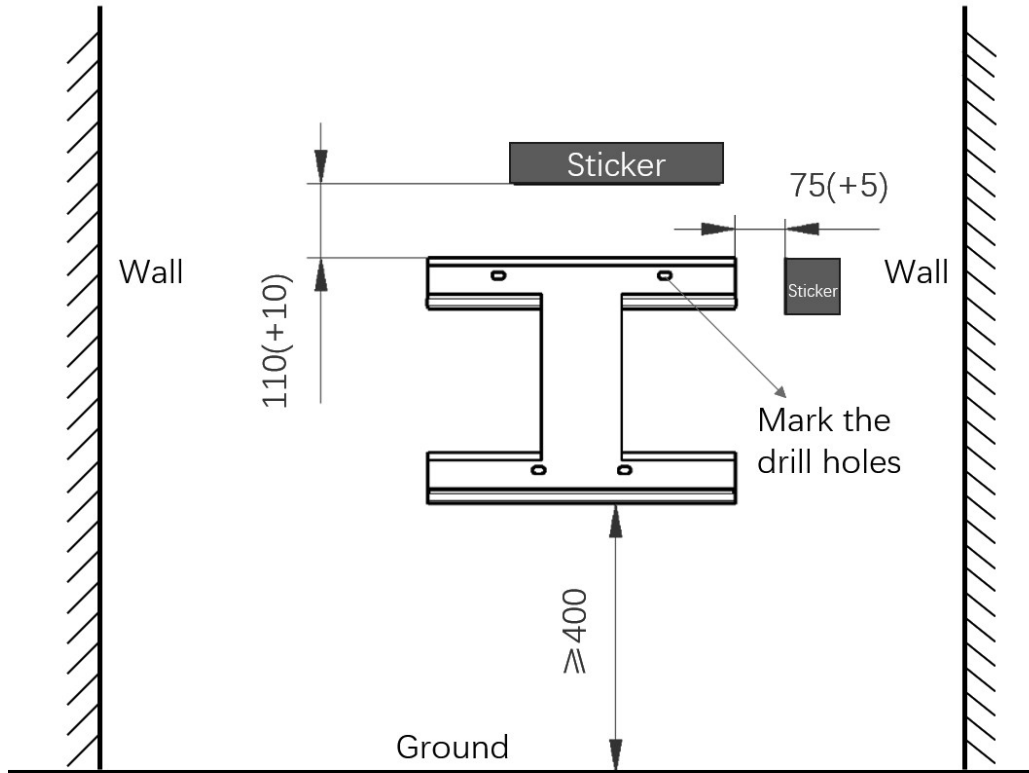

Unit: mm

b) Choose the recommend drill head (as shown in Figure 5-1) to drill 4 holes on the wall, 100mm-110mm deep.

c) Use a proper hammer to fixing the hanging plate to the wall, fit the expansion bolt (M6*100) into the holes, as shown in Figure 5-1.

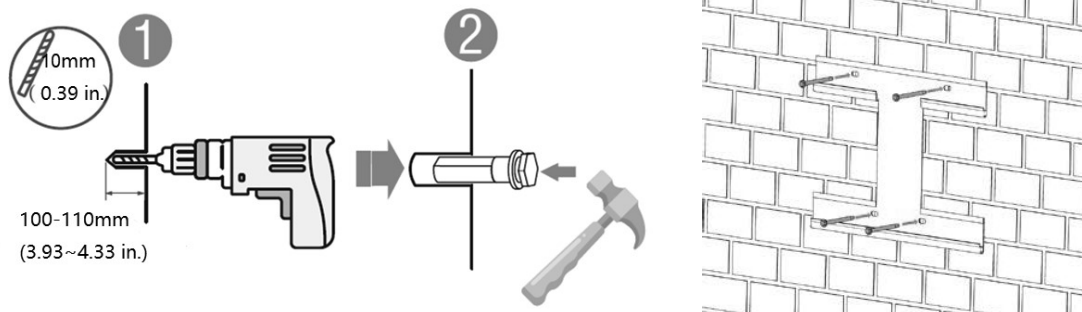

Figure 5-1

d) Use the 8 screws of M6*10 to fix the backplane to the back of the battery as shown in Figure 5-2.

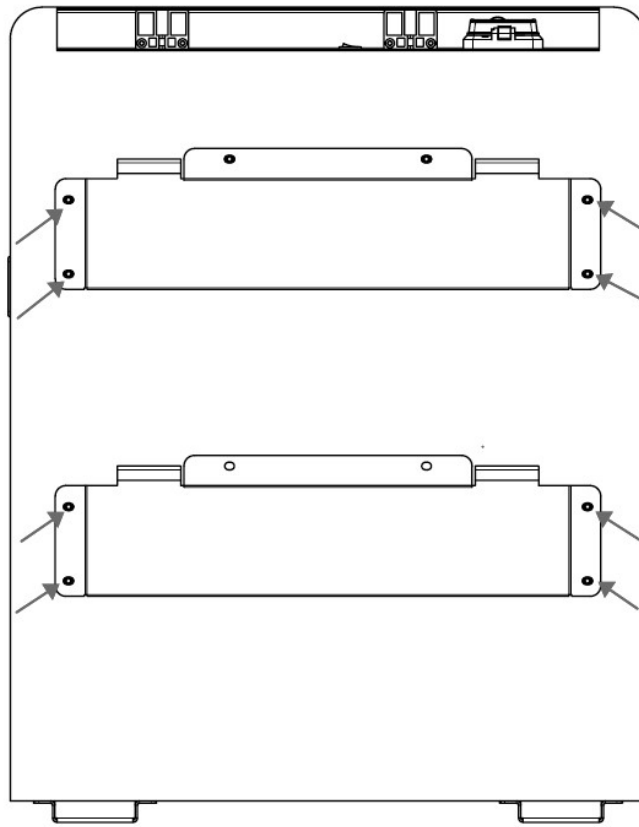
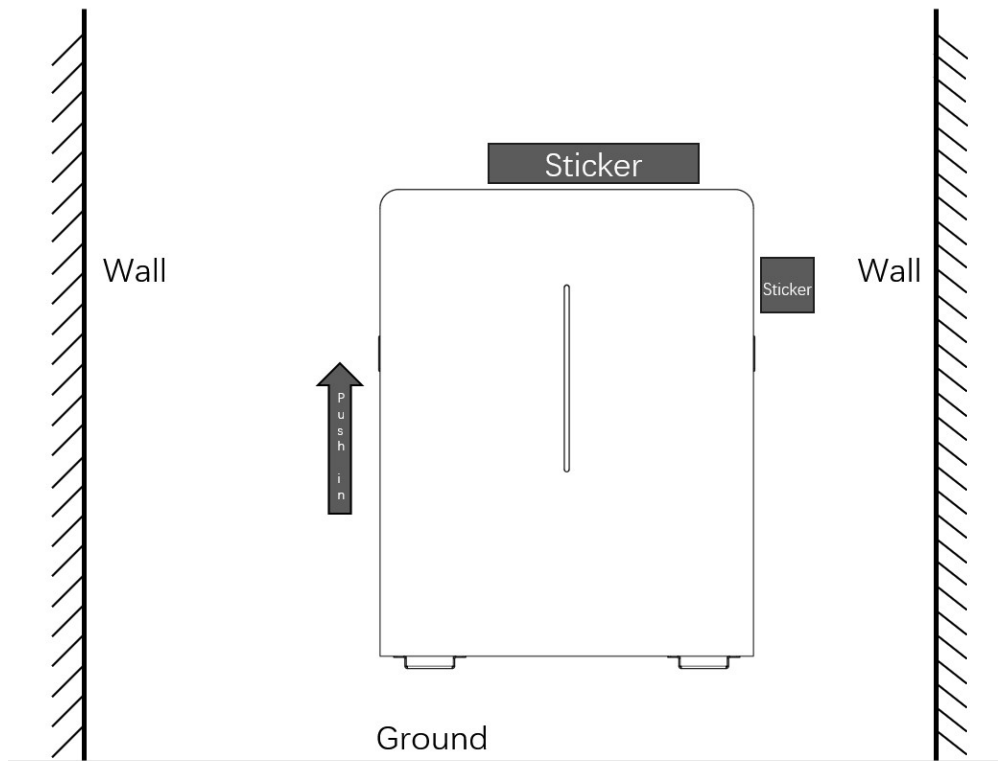

Figure 5-2

e) Then lifting the RW-F10.6 along the position of the sticker , push it on the wall bracket.



Unit: mm

- f) Fasten the screw head of the expansion bolt to finish the mounting.
- g) Carry the battery and holding it, Fix the battery on the plate after fixing the hanging plate to the wall. Ensure that the upper and lower positions of the battery backplane hook are accurately buckled on the hanging plate, as shown in Figure 5-3.

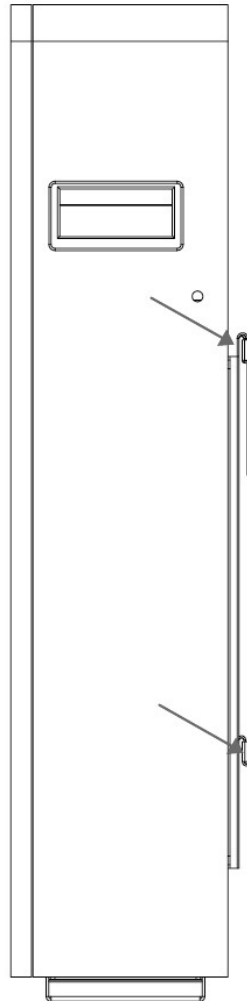

Figure 5-3

5.3.2 Floor-Mounted method

- a) Use the 4 screws of M6*10 to fix the left and right retaining ears to the back of the battery, as shown in Figure 5-4.

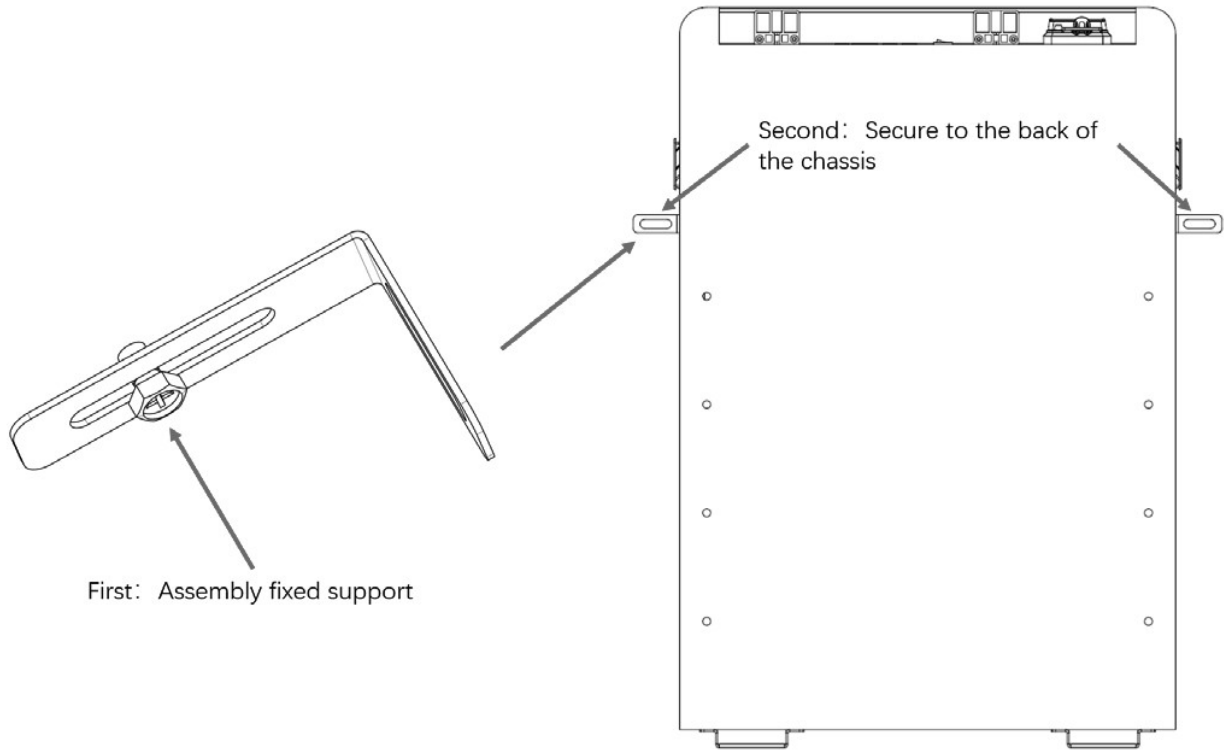

Figure 5-4

b) Stand the battery on the side of the wall, mark the location of the fixing hole, Choose the recommend drill head (as shown in below picture) to drill 2 holes on the wall, 100-110mm deep, as shown in Figure 5-2 and Figure 5-5.

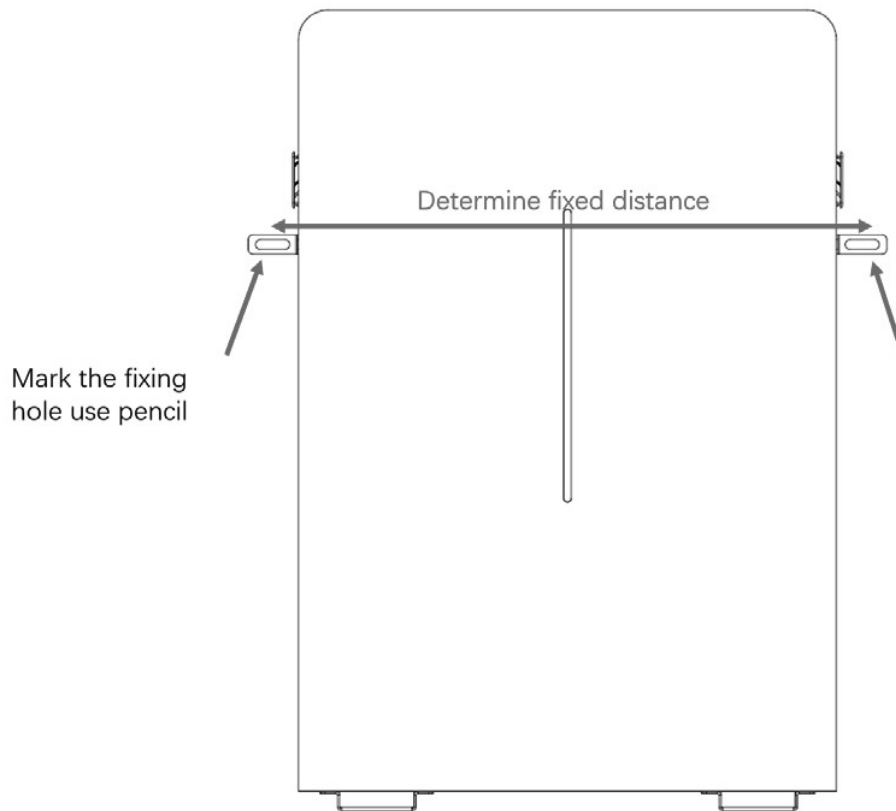

Figure 5-5

c) Use a proper hammer to fix the battery to the wall, fit the expansion bolt into the holes, as shown in Figure 5-2.

d) Adjust the left and right screws to the appropriate position to ensure that the battery is perpendicular to the ground, as shown in Figure 5-6.

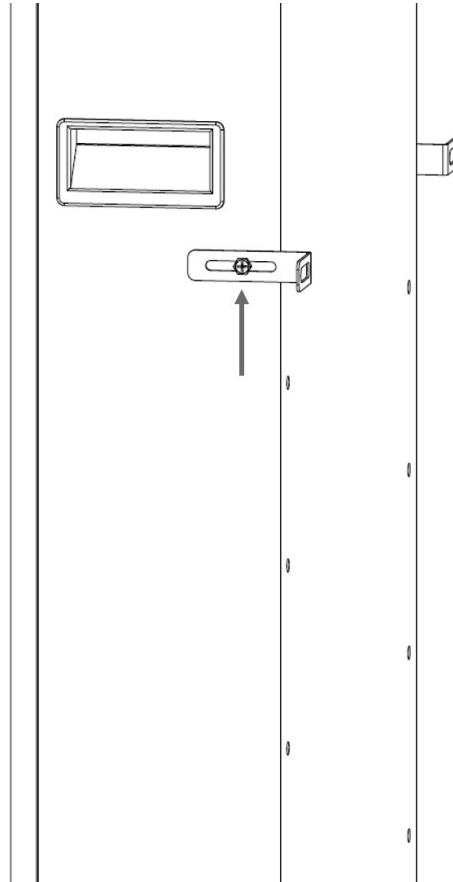

Figure 5-6

5.4 Batteries in parallel

5.4.1 Parallel mode 1 (It is suitable for scenarios where the inverter power $\leq 18\text{kW}$)



It should be noted that the maximum current of the first battery is 350A (inverter power must not exceed 18kW), exceeding 350A will cause heating of the connectors and cable, and in severe cases, it will cause a fire accident.

If the inverter power exceeds 18kW, the parallel mode must be used mode 2!

Schematic diagram of parallel connection of low-power system batteries:

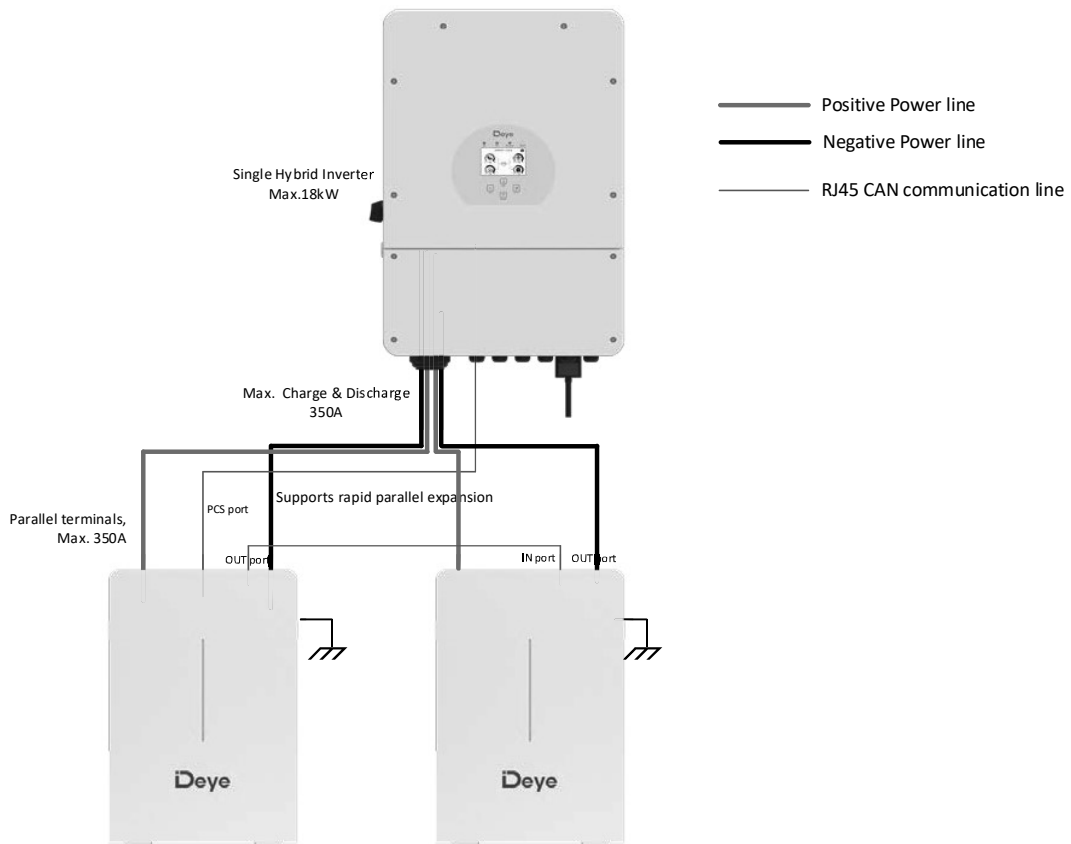

or larger capacity systems:

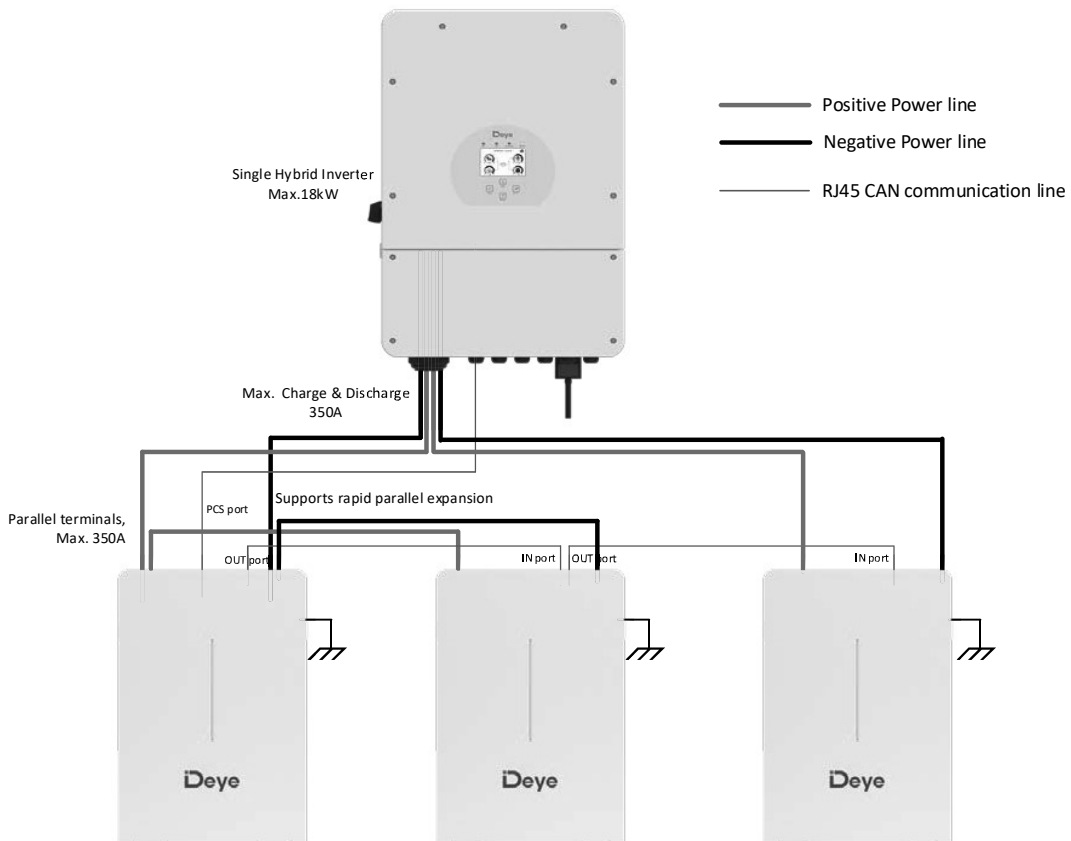

5.4.2 Parallel mode 2 (It is suitable for scenarios where the inverter power > 18kW)

Schematic diagram of parallel connection of high-power system batteries:

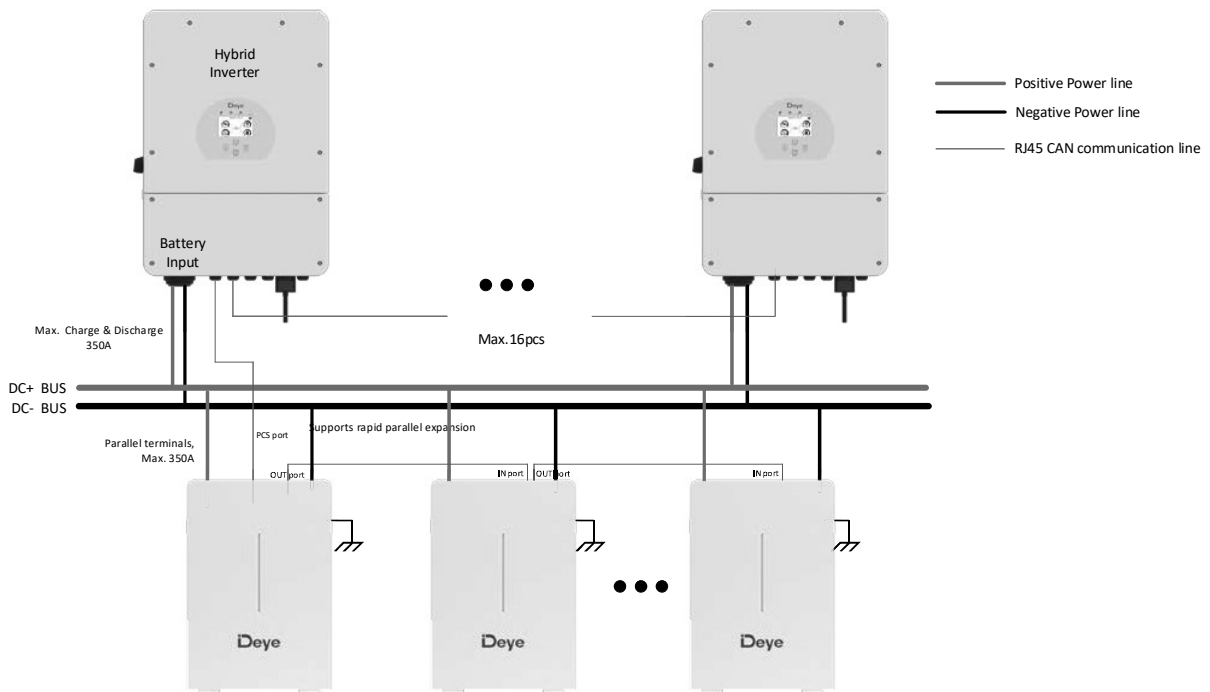

5.5 Visual Inspection of the Connection

After connecting the battery, check for:

- Usage of positive and negative cables.
- Connection of the positive and negative terminals.
- All the bolts are tightened.
- Cables fixation and the appearance.
- The installation of the protecting cover.

5.6 Activate the Product

- A. Hang the RW-F10.6 battery on the wall as shown on 5.4.
- B. Connect the wires according to the picture on 5.4.
- C. Turn on all battery power in turn.

Start the Battery:

After installation, wiring, and configuration are completed, you must check all the connection. When the connections are correctly, and then open the micro circuit breaker and press BMS power button to activate the battery. The green working light on the front panel of the battery flashes, indicating that the battery system is normal.

6 Inspection, Cleaning and Maintenance

6.1 General Information

- The battery product is not fully charged. It is recommended that the installation be completed within 3 months after arrival;
- During the maintenance process, do not re-install the battery in the battery product. Otherwise, the performance of the battery will be reduced;
- It is forbidden to dismantle any battery in the battery product, and it is forbidden to dissect the battery;
- After the battery product is over-discharged, it is recommended to charge the battery within 48 hours. The battery product can also be charged in parallel. After the battery product is connected in parallel, the charger only needs to connect the output port of any product battery.
- Never attempt to open or dismantle the battery! The inside of the battery does not contain serviceable parts.
- Disconnect the Li-Ion battery from all loads and charging devices before performing cleaning and maintenance activities
- Place the enclosed protective caps over the terminals before cleaning and maintenance activities to avoid the risk of contacting the terminals.

6.2 Inspection

- Inspect for loose and/or damaged wiring and contacts, cracks, deformations, leakage, or damage of any other kind. If damage to the battery is found, it must be replaced. Do not attempt to charge or use a damaged battery. Do not touch the liquid from a ruptured battery.
- Regularly check the battery' s state of charge. Lithium Iron Phosphate batteries will slowly self-discharge when not in use or whilst in storage.
- Consider replacing the battery with a new one if you note either of the following conditions:
 - The battery run time drops below 70% of the original run time.
 - The battery charge time increases significantly.

6.3 Cleaning

If necessary, clean the Li-Ion battery with a soft, dry cloth. Never use liquids, solvents, or abrasives to clean the Li-Ion battery.

6.4 Maintenance

The Li-Ion battery is maintenance free. Charge the battery to approximately > 80% of its capacity at least once every year to preserve the battery's capacity.

6.5 Storage

- The battery product should be stored in a dry, cool, and cool environment;
- Generally, the maximum storage period at room temperature is 6 months. When the bat-

tery is stored over 6 months, it is recommended to check the battery voltage. If the voltage is higher than 51.2V, it can continue to store the battery. In addition, it is needed to check the voltage at least once a month until the voltage is lower than 51.2V. When the voltage of the battery is lower than 51.2V, it must to be charged according to the charging strategy.

- The charging strategy is as follows: discharge the battery to the cutoff voltage with 0.2C(42A) current, and then charge with 0.2C(42A) current for about 3 hours. Keep the SOC of the battery at 40%-60% when stored;
- When the battery product is stored, the source of ignition or high temperature should be avoided and it should be kept away from explosive and flammable areas.

7 Troubleshooting

To determine the status of the battery system, users must use additional battery status monitoring software to examine the protection mode. Refer to the installation manual about using the monitoring software. Once the user knows the protection mode, refer to the following sections for solutions.

Table 7-1: Troubleshooting

Fault Type	Fault Generation condition	Possible Causes	Troubleshooting
BMS fault	The cell voltage sampling circuit is faulty. The cell temperature sampling circuit is faulty	The welding point for cell voltage sampling is loose or disconnected. The voltage sampling terminal is disconnected. The fuse in the voltage sampling circuit is blown. The cell temperature sensor has failed.	Replace the battery.
Electrochemical cell fault	The voltage of the cell is low or unbalanced.	Due to large self- discharge, the cell over discharges to below 2.0V after long term storage. The cell is damaged by external factors, and short circuits, pin-pricks, or crushing occur.	Replace the battery.
Overvoltage protection	The cell voltage is greater than 3.65 V in charging state. The battery voltage is greater than 58.4 V.	The busbar input voltage exceeds the normal value. Cells are not consistent. The capacity of some cells deteriorates too fast or the internal	If the battery cannot be recovered due to protection against abnormality contact local

		resistance of some cells is too high.	engineers to rectify the fault.
Under voltage protection	The battery voltage is less than 40V. The minimum cell voltage is less than 2.5V	The mains power failure has lasted for a long time. Cells are not consistent. The capacity of some cells deteriorates too fast or the internal resistance of some cells is too high.	Same as above.
Charge or discharge high temperature protection	The maximum cell temperature is greater than 60°C	The battery ambient temperature is too high. There are abnormal heat sources around	Same as above.
Charge low temperature protection	The minimum cell temperature is less than 0°C	The battery ambient temperature is too low.	Same as above.
Discharge low temperature protection	The minimum cell temperature is less than -20°C	The battery ambient temperature is too low.	Same as above.

By checking the above data and sending the data to the service personnel of our company, the service personnel of our company will reply the corresponding solution after receiving the data.

8 Battery recovery

Aluminum, copper, lithium, iron, and other metal materials are recovered from discarded LiFePO₄ batteries by advanced hydrometallurgical process, and the comprehensive recovery efficiency can reach 80%. The specific process steps are as follows:

8.1 Recovery process and steps of cathode materials

Aluminum foil as collector is amphoteric metal. Firstly, it is dissolved in NaOH alkali solution to make aluminum enter the solution in the form of NaAlO₂. After filtration, the filtrate is neutralized with sulfuric acid solution and precipitated to obtain Al(OH)₃. When the pH value is above 9.0, most of the aluminum precipitates, and the obtained Al(OH)₃ can reach the level of chemical purity after analysis.

The filter residue is dissolved with sulfuric acid and hydrogen peroxide, so that lithium iron phosphate enters the solution in the form of Fe₂(SO₄)₃ and Li₂SO₄, and is separated from carbon black and carbon coated on the surface of lithium iron phosphate. After filtration and separation, the pH value of the filtrate is adjusted with NaOH and ammonia water. First, iron is precipitated with Fe(OH)₃, and the remaining solution is precipitated with saturated

Na₂CO₃ solution at 90 °C.

Since FePO₄ is slightly dissolved in nitric acid, the filter residue is dissolved with nitric acid and hydrogen peroxide, which directly precipitates FePO₄, separates impurities such as carbon black from acid solution, leaches Fe (OH)₃ from filter residue respectively, and precipitates Li₂CO₃ with saturated Na₂CO₃ solution at 90 °C.

8.2 Recovery of anode materials

The recovery process of anode materials is relatively simple. After the separation of anode plates, the purity of copper can be more than 99%, which can be used for further refining electrolytic copper.

8.3 Recovery of diaphragm

The diaphragm material is mainly harmless, and has no recycling value.

8.4 List of recycling equipment

Automatic dismantling machine, pulverizes, wet gold pool, etc.

9 Transportation Requirements

The battery products should be transported after packaging and during the transportation process, severe vibration, impact, or extrusion should be prevented to prevent sun and rain. It can be transported using vehicles such as cars, trains, and ships.

Always check all applicable local, national, and international regulations before transporting a Lithium Iron Phosphate battery.

Transporting an end-of-life, damaged, or recalled battery may, in certain cases, be specially limited or prohibited.

The transport of the Li-Ion battery falls under hazard class UN3480, class 9. For transport over water, air and land, the battery falls within packaging group PI965 Section I.

Use Class 9 Miscellaneous Dangerous Goods and UN Identification labels for transportation of lithium-ion batteries which are assigned Class 9. Refer to relevant transportation documents.



Figure 9-1: Class 9 Miscellaneous Dangerous Goods and UN Identification Label