

Consumer Warranty -25.6V/51.2V LiFePO4 battery

1. Consumer Laws

If you acquire the Product from an Authorised Reseller in South Africa and the Consumer Law applies, the Product comes with guarantees that cannot be excluded under the South Africa Consumer Law. You are entitled to a replacement for a major failure and compensation for any other reasonably foreseeable loss or damage. You are also entitled to have the goods repaired or replaced if the goods fail to be of acceptable quality and the failure does not amount to a major failure.

The benefits provided by this Warranty are in addition to all other rights and remedies in respect of the Product which You have under the Consumer Law or any other law that cannot be excluded.

2. Product Warranty

BSLBATT warrants that the Product will be free of defects caused by improper workmanship or defective materials.

BSLBATT Batteries models enjoy this warranty item as below

B-LFP24-200	25.6V 200AH
B-LFP48-100	51.2V 100AH
B-LFP48-125	51.2V 125AH
B-LFP48-135	51.2V 135AH
B-LFP48-160	51.2V 160AH
B-LFP48-172	51.2V 172AH
B-LFP48-200	51.2V 200AH
B-LFP48-300	51.2V 300AH

This warranty commences the period of Ten (10) years from the earlier of:

1. The date of installation of the Product;
2. Six (6) months after the date the Product was manufactured,

(Warranty Period) subject to the conditions in clause 3 and the Exclusions in clause 5. This warranty does not include any accessories and tool kit items provided with the Product.

BSLBATT will repair or replace the Product if the Product is defective and returned during the Warranty Period.

A BSLBATT battery is supplied with a 10-year limited warranty from the date of purchase (please keep your proof of purchase) or 4000 battery cycles at a maximum depth of discharge of 80%, whichever comes first.

The integrated battery management system (BMS) is capable of calculating and recording the aggregate number of cycles that have been completed by the battery where one complete cycle in terms of this warranty is a discharge from 100% State of Charge (SoC) to 20% SoC – which is equivalent to 80% Depth of Discharge (DoD) – followed by a charge again to 100% SoC. Discharges deeper than 80% DoD and less than 80% DoD are also counted into to the total number of cycles on a pro rata basis.

The 10-year limited warranty period assumes no more than one full cycle per 24hr period. In the event of a valid warranty claim the manufacturer will, at its discretion, supply a new or re-conditioned BSLBATT battery dependent on how many years have passed since the date of purchase or how many cycles the battery has undertaken.

Connected BSL batteries manually without communication

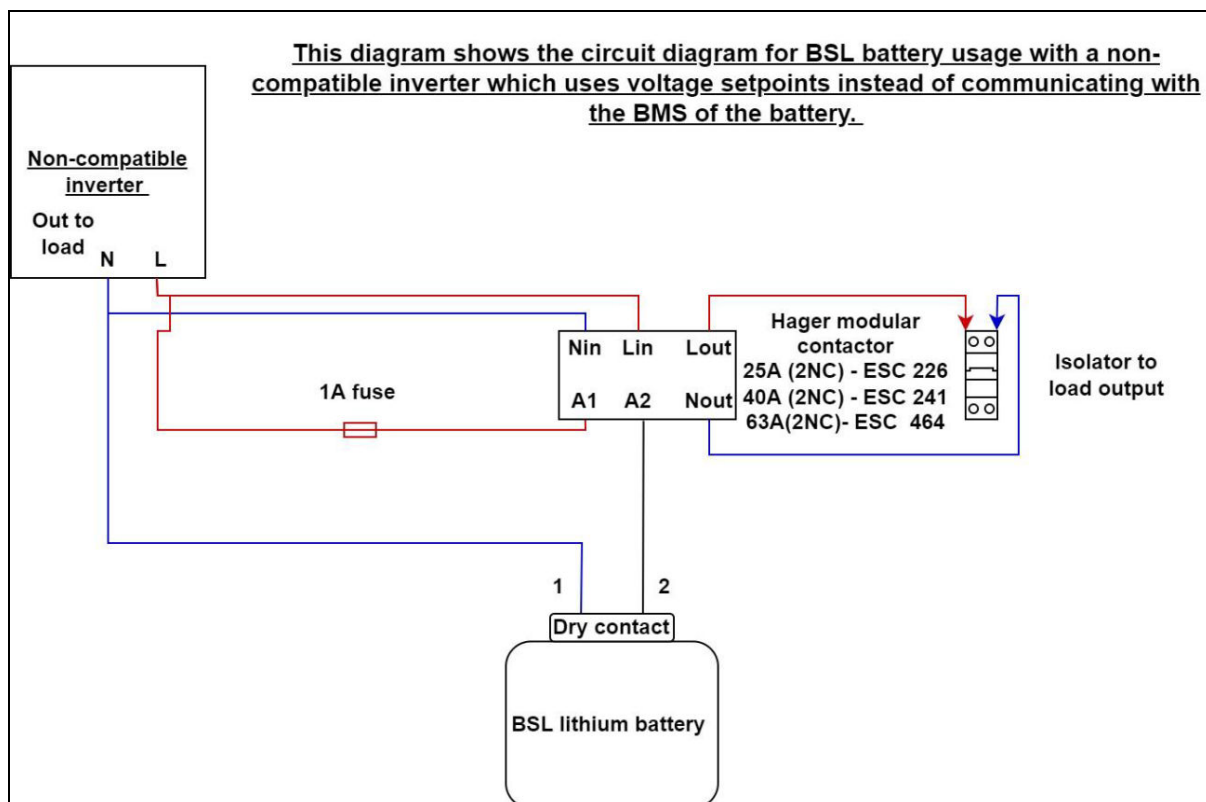

Specified contactor must be used when manually [voltage based] connecting BSL lithium batteries to noncompatible Inverter. Warranty remains for 120 months. If specified contactor is not used, warranty period is 60 months.

One cycle is defined as a complete charge and discharge. Meaning that a complete charge of 100% and discharge of 100% is achieved to equal 1 complete cycle. In most cases a lithium battery will be

discharged to 80% therefore leaving a remaining 20%. This information is stored in the battery BMS and upon its next charge and re-charge the 1 cycle will be calculated.

BSL LiFePO4 batteries can be cycled multiple times a day without affecting the warranty.

The warranty conditions set out are 10 years / 4000 cycles @ 80% DoD or 10 years / 3000 cycles @ 100%.

Free Replacement (months)	Repairs (months)	Total Warranty (months)
60	60	120

3. Warranty Claims

1. Contact the original point of purchase for instructions.
2. The battery must only be returned in compliance with the transport and packaging regulations ruling at the date of return. Failure to do this may result in the carrier refusing to ship the battery.
3. Free replacement: BMS, CELLS, New battery depend on the battery status.
4. Repair: we will provide the necessary training and materials: BMS, CELLS, Accessories to local distributors. Then our local agent will help customers to maintain the batteries

4. Warranty Conditions

The warranties in respect of the Product only apply if the Product.

1. Is purchased from BSLBATT or an Authorised Reseller in the Territory.
2. Has the official BSLBATT serial number.
3. Is installed in a battery module in the Territory.
4. Is installed, operated and maintained in accordance with the Product Instructions.
5. Be used on a daily cycle basis and only for energy storage system.
6. The firmware of battery must be updated to special firmware version, such firmware is available from BSLBATT, or Authorised Reseller.
7. If there is no communication, including on grid or off grid, the inverter settings must be confirmed by BSLBATT, or Authorised Reseller.
8. Working temperature: 0°C~45°C charging and -10°C~45°C discharging.
9. The seal is protected well on the battery casing.

The warranty would be inapplicable if the defect in or failure of the Product's performance is attributable to your misuse, abuse, accident or non-observance of the Product

5. Claim

Claims can be made to the Authorised Reseller from whom the Product was purchased or from BSLBATT directly.

You must, within 48 hours of a defect being discovered, notify BSLBATT of a claim by:

1. If You registered the Product, completing the claim form on the BSLBATT website;
2. If You did not register the Product, completing the warranty card provided with the Product at the time of purchase and either emailing a copy to BSLBATT at the below email address, or delivery or emailing the warranty card to the Authorised Reseller from whom the Product was purchased.

In order to claim under this Warranty, You must:

1. Present the certificate of warranty declaration in its original form;
2. Submit the invoice for the procurement of the Product indicating the date of delivery;
3. Provide the BSLBATT system log data recorded by the Product as an indication of whether or not the Minimum Capacity has been achieved (but this would not be determinative).

To make a claim to BSLBATT directly, please contact:

Address: Mainland Office: 608, Zhonghui International Mansion, Shiminleyuan E Rd, Huicheng District, Huizhou, Guangdong Province, China.

Telephone : +86 0752 2819 469

Mob: +86 188 2486 5778

Email: inquiry@bsl-battery.com

BSLBATT may contact You for further information regarding a defect. BSLBATT may require You to complete root analysis testing of the Product to provide evidence supporting the claim. Final verification of the claim will be made by BSLBATT.

If You dispute BSLBATT's verification of the claim, the Product must be evaluated by an South Africa government certified testing lab or a certified 3rd party testing company. You will bear the cost of any 3rd party evaluation service charge (unless your claim is proven to be valid, in which case BSLBATT will be responsible for the testing costs).

If any testing of the Product's capacity is required, the testing must occur in the following conditions

- a) The ambient temperature of the Product must be 25oC±2oC
- b) The initial temperature of the battery pods must be 25oC±1oC
- c) Power shall be discharged by the Product at 10A as measured at the 56-57V DC link from an initial 100% charge capacity.

If the Product is no longer available, BSLBATT may, at its discretion, replace the Product with a refurbished product or different product or parts with equivalent functions and performance according to the latest technical information available.

6. Exclusions of Warranty

To the extent permitted by law, BSLBATT excludes all liability for the Product to the extent that any damage or defect has been caused or contributed to by the following:

1. If the seal is broken on the battery casing.
2. Inverter or charger failure;
3. The Product being installed with inverters or charger which have not been certified by BSLBATT;
4. You treat the Product improperly, negligently or in any other inappropriate way, including using the
 - a) Product outside the recommended ambient temperature condition in accordance with the Product Instructions;
5. Transportation, including but not limited by dropping, trampling, deforming, impacting, or spearing with a sharp item;
6. Storage, installation, commissioning, modification or repair of the Product that has been performed by a person other than BSLBATT or a BSLBATT's certified installer;
7. Abuse, misuse, negligence, accidents or force majeure events, including but not limited to lightning, flood, fire, extreme cold weather, or other events outside the reasonable control of BSLBATT;
8. Any attempt to extend or reduce the life of the product without written confirmation from BSLBATT, whether by physical means, programming or others;
9. Removal and reinstallation at another place from the original installation without the written confirmation from BSLBATT;
10. Water, conductive dust or corrosive gas;
11. The Product has been connected with different type battery modules;
12. Failure to install, operate or maintain the product in accordance with the Product Instructions;
13. Normal wear and tear or deterioration, or superficial defects, dents or marks that impact the performance of the Product;
14. Theft or vandalism of the Product or any of its components

7. General Provisions

This warranty is subject to the law of the South Africa.

If any provision in this document is unenforceable, illegal or void or makes this document or any part of it unenforceable, illegal or void, then that provision is severed and the rest of this document remains in force.

If any provision in this document is unenforceable, illegal or void in 1 jurisdiction but not in another jurisdiction or makes this document or any part of it unenforceable, illegal or void in 1 jurisdiction but not in another jurisdiction, then that provision is severed only in respect of the operation of this document in the jurisdiction where it is unenforceable, illegal or void.

8. Definitions

In this document:

1. Authorised Reseller means an approved BSLBATT retailer or distributor in the Territory.
2. Consumer Law means: South Africa Consumer Law
3. Minimum Capacity means at least 70% of the Nominal Capacity at the end of 7 years of Warranty Period. And Minimum Capacity of 10 years of Warranty Period would be not less than 60% of the Capacity at the end of 7 years Warranty Period.
4. Nominal Energy means the initially rated capacity of the Product as printed on the label of the Product.
5. Product means 25.6V/51.2V LiFePO4 batteries manufactured by BSLBATT;
6. Product Instructions means the instructions and manuals issued by BSLBATT with the Product that set out how the Product should be installed and operated.
7. BSLBATT means WISDOM INDUSTRIAL POWER Co.,LTD. Address:
Mainland Office: 608, Zhonghui International Mansion, Shiminleyuan E Rd, Huicheng District, Huizhou, Guangdong Province, China.
8. Territory means all the countries in South Africa, depending on where the Product was purchased.
9. You means the natural person that acquired the Product.

Thank you for purchasing this advanced Lithium Iron Phosphate (LiFePO4) battery

A few tips on how to get the best from your BSLBATT battery:

- ★ Protect the battery from direct sunlight although it will work well in a wide temperature range (-20 to 60 degrees C).
- ★ Avoid using BSLBATT in damp or wet conditions but if you do need to use it in these conditions consider using an all-weather enclosure (not included in package).
- ★ Observe the correct polarity otherwise permanent damage could be caused - the battery casing is marked with + and -.
- ★ Don't short circuit BSLBATT otherwise permanent damage could be caused.
- ★ BSLBATT can be connected in Parallel.
- ★ BSLBATT cannot be connected in Series.

Please note when connecting multiple batteries, you must first fully charge each battery and check they don't have a voltage difference of more than 0.005V (5mV).

★ Most Mains lead acid battery chargers will charge the BSLBATT, but some smart chargers might only charge up to 85%. If this is the case, we recommend getting a new specific LiFePO4 battery charger (not included in package). However, you will not cause any damage to the battery if using your old charger. For DC - DC charging please follow DC-DC charger's instructions of charging to lead acid battery if it has not LiFePO4 battery charge mode.

★ Keep BSLBATT battery is positioned with its terminals facing upward.

NOTE - Do not mix new BSLBATT batteries with old batteries, whether in series or parallel

9. Storage of BSLBATT Battery

BSLBATT battery has an extremely low rate of self-discharge but if you intend not to use the battery for an extended period of time, please fully charge it prior to storage. It is recommended to re-charge the BSLBATT battery once every 6 months. NOTE - Allowing the battery to over discharge (+6 months since its last charge) can lead to a shortened life.

10. Connecting your BSLBATT battery

When connecting to the BSLBATT using the nuts and washers provided. Please connect the Positive (+) connection first before connecting the Negative (-) connection. Disconnections is the reverse process, Negative (-) first, Positive (+) last.

11. Disposal

Disposal of a used or damaged BSLBATT battery must be done at a certified recycling location. There are many of these nationwide - please contact us for help if necessary

12. BSLBATT Safety and Product Limitations

- ※ Keep out of the reach of children and pets.
- ※ Do not under any circumstances disassemble this battery.
- ※ Do not immerse the battery in liquid.
- ※ Do not use the battery with damaged cables or terminals.
- ※ This battery is not designed for cranking and starter applications.
- ※ Do not expose the battery to fire or crush or puncture its casing.
- ※ Do not mix BSLBATT batteries with other brands of batteries, whether in series or parallel

13. Contact Way

Bella Chen

EMEA Sales Manager

WISDOM INDUSTRIAL POWER Co.,LTD

Office Tel: 0086-752-2819469

Mob: 0086 188 2486 5778 (WhatsApp/ Wechat No.)

Skype: bellachen2015

Email: sales04@bullsbattery.com

Lead acid battery Web: www.bullsbattery.com

Lithium battery Web: www.lithium-battery-factory.com

Mainland Office: 608, Zhonghui International Mansion, Shiminleyuan E Rd, Huicheng District, Huizhou, Guangdong Province, China.

HK address: FLAT/RM 92 3/F ETON TOWER 8 HYSAN AVENUE CAUSEWAY BAY HK